

# RAILBEAST®

**JEI**  
Solutions  
Built for Industry

## RDP-36

**A VERY POWERFUL COMPACT AND LIGHT WEIGHT MACHINE EQUIPPED WITH PETROL HONDA 4-STROKE ENGINE FOR DRILLING IN RAILS.**

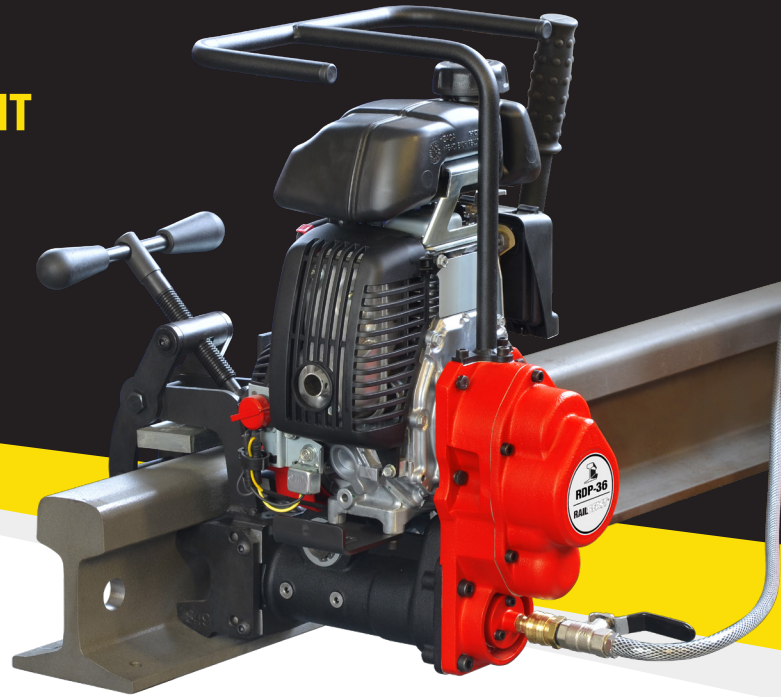

**Core drill: max 36 mm (1-7/16")**



**Twist drill: max 16 mm(5/8")  
with Weldon Shank 19mm (3/4")**



**Depth of cut: up to 30 mm (1-3/16")**



**Stroke: 39 mm (1-1/2")**

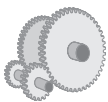

**Speed: 225 rpm**



**Motor Power: 1500 W**



**Weight: 18.5 kg (40.8 lbs)**

Fast positioning, quick clamping and instant unlocking mechanisms make it easy to use and safe device.

RDP-36 enables drilling in rails of any standard by means of 2pcs of optional rail profile templates and 1pcs of hole centre positioner, to be chosen by customers from a comprehensive range of auxiliary accessories dedicated to a variety of types of rails.

Pressure Coolant system including 5l bottle enables forced feeding of cooling medium in any drilling positions. It is ideal solution when gravitational feeding fails

RDP-36 can also be ordered with electric motor as RDP-36. It weighs only 18,5 kg (40,8 lbs).

**CALL 01706 229 490 TO BOOK YOUR DEMONSTRATION NOW OR VISIT [WWW.JEIUK.COM](http://WWW.JEIUK.COM)**



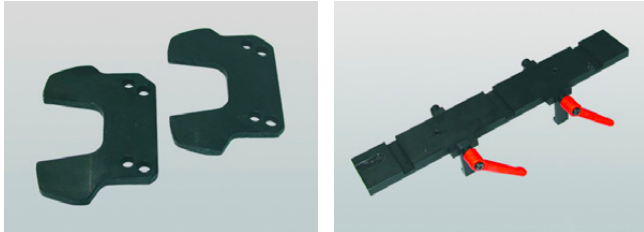

### RAIL PROFILE TEMPLATES AND HOLE CENTRE POSITIONER ARE TO BE ORDERED, SEPARATELY.

Upon customer's request any rail profile templates and hole centre positioners are subject to manufacture to meet any required rail standard.

RDP-36 TECHNICAL SPECIFICATION	
Spindle	Arbor 19 mm; 3/4" Weldon
Tool Holder	
Max milling capacity	Ø 36 mm (1 7/16")
Max drilling capacity	Ø 16 mm (5/8")
Stroke	39 mm (1 1/2")
Max depth of cut	30 mm (1 3/16")
Motor type	4-stroke petrol engine
Power consumption	1500 W
Motor Power	1500 W
Speeds	225 rpm
Weight	18.5 kg (40.8 lbs)
Product Code	DRILL-RAIL/P

### RAIL PROFILE TEMPLATES:

**UIC54 Template** RAIL-TEMPUIC54  
**UIC60 Template** RAIL-TEMPUIC60  
**P50 Template** RAIL-TEMPP50  
**P65 Template** RAIL-TEMPP65  
**S49 Template** RAIL-TEMPS49

### HOLE CENTRE POSITIONERS:

**UIC54 Positioner** RAIL-POSUIC54  
**UIC60 Positioner** RAIL-POSUIC60  
**P50 Positioner** RAIL-POSP50  
**P65 Positioner** RAIL-POSP65  
**S49 Positioner** RAIL-POSS49

### STANDARD SHIPPING SET

- ✓ Rail Drilling Machine
- ✓ Metal Box
- ✓ Pressure Coolant 5l Bottle Assembly
- ✓ Set of Tools
- ✓ Instruction Manual (English)
- ✓ Standard shipping weight – 40 kg (86 lbs 5 oz)

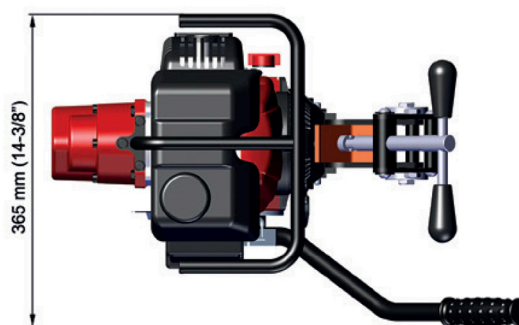
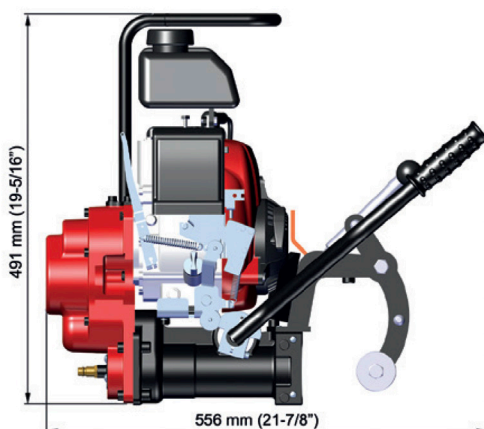

CALL 01706 229 490 TO BOOK YOUR DEMONSTRATION NOW OR VISIT [WWW.JEIUK.COM](http://WWW.JEIUK.COM)