

# STEEL BEAST®

# PRO-152T

## HEAVY DUTY TAPPING AND DRILLING MACHINE



**Core drill max 150 mm (6")**



**Twist drill max 47 mm (1-7/8")**



**Spindle MT4**



**Depth of cut 100 mm (4")**



**Stroke 260 mm (10")**



**Speed 55-85 rpm, 100-150 rpm  
200-300 rpm, 350-520 rpm**



**Motor Power 2300 W**



**Weight 31 kg (68 lbs)**



**Thread cutting M42 (1-5/8")**



**Worn brushes indicator**



**Thermal/overheat protection**



**Overload protection**

**PART OF A NEW GENERATION RANGE OF PREMIUM PORTABLE MAGNETIC DRILLING SOLUTIONS, DESIGNED TO MAXIMISE PRODUCTIVE DRILLING.**

The PRO-152T drilling machine is designed for large hole making and very big tapping applications. The powerful 2300 W variable speed motor enables milling capacity up to 150 mm (6") and drilling capacity up to 47 mm (1-7/8").

The machine's forward and reverse work modes allow thread cutting up to M42 with a new tapping system.













The four-speed gearbox with continuous speed adjustment allows to set the optimal speed depending on diameter, steel grade or tool quality. An intelligent speed control system maintains constant motor speed regardless of changing loads. The innovative 360-degree LED indicator facilitates proper machine operation and increases work safety.

CALL **01706 229 490** TO BOOK YOUR DEMONSTRATION NOW OR VISIT **WWW.STEELBEAST.CO.UK**

- ✓ 2300 W powerful motor with heavy duty 4-speed gearbox
- ✓ Intelligent speed control system maintains stable speed regardless of load changes
- ✓ Tapping of through and blind holes
- ✓ Milling with TCT or HSS cutters or drilling
- ✓ Electronic speed control
- ✓ Electronic clutch
- ✓ Rigid design extends tool life
- ✓ Tilt sensor stops the motor in cases of machines break away
- ✓ 360 degree visual monitoring system indicates current condition of the drill and gives safety and diagnostic information, e.g. worn brushes
- ✓ Innovative smart magnet with reduced weight
- ✓ Intuitive control panel at top of the drill
- ✓ Large coolant container



### 360-DEGREE VISUAL MONITORING SYSTEM (VMS) - HOW IT WORKS

 <b>CONDITION OF THE DRILL</b>		ready to work (green is on)
		normal work (white is on)
		overheat (red is on)
		emergency stop/overload (blue is on)
		emergency stop/tilting the machine due to vibrations or weak surface (violet is on)
 <b>SAFETY INFORMATION</b>		low adhesive force (green flashes)
		near overload (blue flashes)
 <b>DIAGNOSTIC INFORMATION</b>		emergency stop/ voltage drop (red changes to blue)
		emergency stop/ worn brushes (red changes to green)

CALL **01706 229 490** TO BOOK YOUR DEMONSTRATION NOW OR VISIT [WWW.STEELBEAST.CO.UK](http://WWW.STEELBEAST.CO.UK)



Milling capacity up to 150 mm (6")  
Max depth of cut up to 100 mm (4")



Drilling capacity up to 47 mm (1-7/8")  
Max stroke up to 260 mm (10")



Counter-clockwise (CCW) rotation  
User-friendly control of tapping tool release

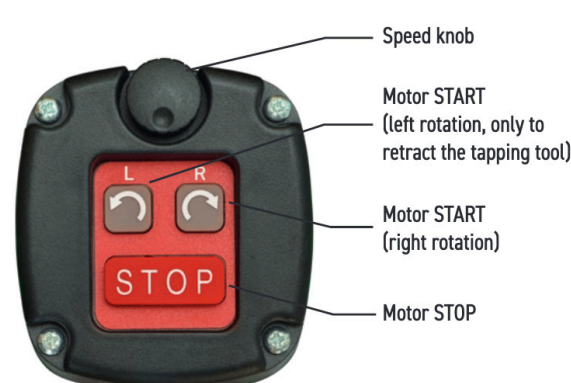

Intuitive control panel at top of the drill

## THROUGH HOLE TAPPING UP TO M42



CALL **01706 229 490** TO BOOK YOUR DEMONSTRATION NOW OR VISIT **WWW.STEELBEAST.CO.UK**



PRO-132T TECHNICAL SPECIFICATION	
Motor Speeds (under load)	55-85 rpm (gear I)
	100-150 rpm (gear II)
	200-300 rpm (gear III)
	350-520 rpm (gear IV)
Motor Power	2300 W
Weight	31 kg (68 lbs)
Max milling capacity	150 mm (6")
Max drilling capacity	47 mm (1-7/8")
Max Tap size	M42 (1-5/8")
Stroke	260 mm (10")
Max depth of cut	100 mm (4")
Voltage	1~ 220-240 V, 50-60 Hz 1~ 110-120 V, 50-60 Hz
Magnetic clamping force (surface with the thickness of 25 mm and roughness Ra = 1.25)	2550 kG (25 000 N)
Magnet Base Dimensions	105 mm × 315 mm × 50 mm 4-1/8" × 12-3/8" × 2"
Min. Workpiece Thickness	10 mm (3/8")
Spindle	MT4
Tool holder	19 mm (3/4") or 32 mm (1-1/4") Weldon
Product Code 220-240 V, 50-60 Hz	WRT-0583-10-20-00-0
Product Code 110-120 V, 50-60 Hz	WRT-0583-10-10-00-0

Dimensions:

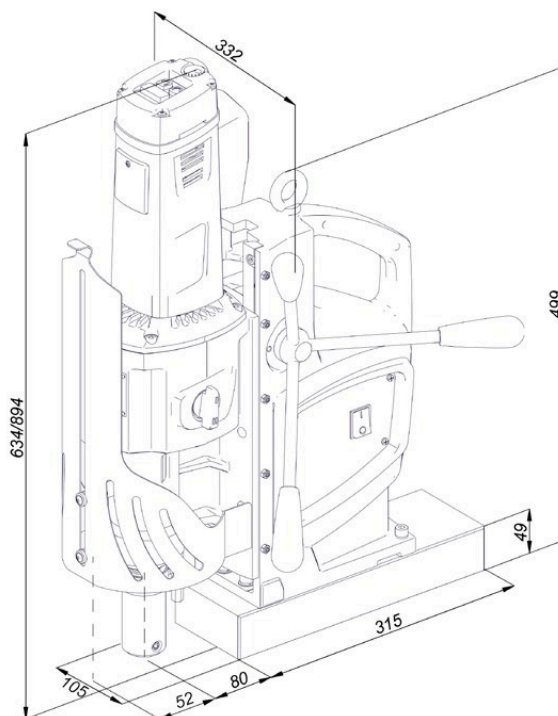

\* If more than 60 mm (2.36"), use an MT4 arbor with 32 mm Weldon tool holder (UCW-583-13-00-00-0).

## STANDARD SHIPPING SET

- ✓ Drilling machine
- ✓ Metal box
- ✓ Handle (3pcs)
- ✓ MT4 arbor with 19 mm (3/4") Weldon tool holder
- ✓ Safety strap
- ✓ Cooling system
- ✓ Protective spring for cooling hose
- ✓ MT4 drift
- ✓ 6 mm hex wrench
- ✓ 5 mm hex wrench with a handle
- ✓ 2.5 mm hex wrench
- ✓ 8 mm combination wrench
- ✓ Tool can
- ✓ Locking connector (only in 115 V version)
- ✓ Operator's manual

## MORE OPTIONAL ACCESSORIES



Arbor MT4 x 32 mm Weldon  
for drilling diameter over 60 mm (2.3")  
product code: UCW-0583-13-00-00-0



Pressure cooling system  
capacity of 2 liters  
product code: UKL-0440-16-00-00-0



CALL **01706 229 490** TO BOOK YOUR DEMONSTRATION NOW OR VISIT **WWW.STEELBEAST.CO.UK**